

## WIRING DIAGRAM

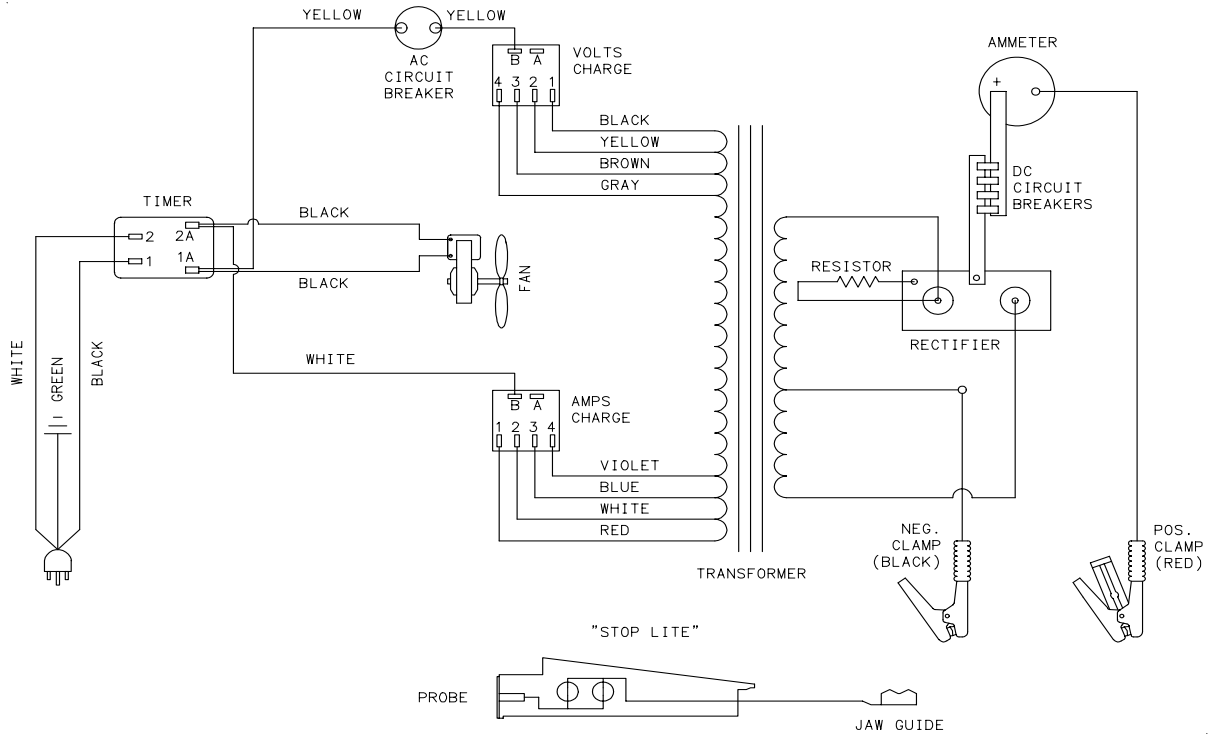

## MODEL 6002B PARTS LIST

Front leg .....	610864	AC Circuit Breaker .....	610397	Side Panel (1).....	605209
Wheels w/nuts (2).....	610553	Timer w/knob .....	610895	Front Panel.....	611075
Axle w/nuts .....	605673	Switch w/knob .....	605675	Back Panel .....	611076
Base .....	605186	Amps Charge Meter.....	605204	Lid.....	605211
Transformer.....	611072	AC Cord .....	611133	Handle .....	610753
Rectifier .....	611073	DC Cable Set.....	611074	Stop/Go Lite .....	604579
Fan Blade.....	610189	DC Circuit Breaker (1) .....	610069	Clamps (1 pair, includes jaws) ...	6202
Fan Motor .....	610190	Top Panel .....	611132	Jaw kit (repairs 1 clamp) .....	610970

Parts may be purchased from your local authorized service center (see service procedure at the end of this manual). If you elect to order parts from the factory you may do so by mail or phone. Minimum order from the factory is \$25.00. Orders received that are under the minimum will not be processed. Taxes and freight are extra and are not considered to be part of the dollar value of the order. We **do not** have a C.O.D. policy. Cashier check, Money order, MasterCard or VISA are acceptable. If you use a MasterCard or VISA send only the number and expiration. **DO NOT SEND THE CARD.**

### MAINTENANCE INSTRUCTIONS

Worn clamps and jaws should be replaced. Worn parts can lead to poor connections and present a safety hazard. See parts list for part number of jaw and clamp kits. Any Maintenance or repair of this unit that involves disassembly of the cabinet should be done only by a qualified serviceman. Incorrect reassembly may result in a risk of electric shock when the unit is subsequently used.